

DEEP TRITON Series

MAKE A CHANGE in Deep Hole Drilling

COMING SOON

High technology based on BTA know-how

NEW Insert!

TRITON Insert



for Gundrill Machine
TRITON LONG

L/D $\geq 26 \sim$
 $\varnothing 16 \sim 25\text{mm}$

for Lathe & M/C
MC TRITON

L/D=8~25
 $\varnothing 16 \sim 25\text{mm}$

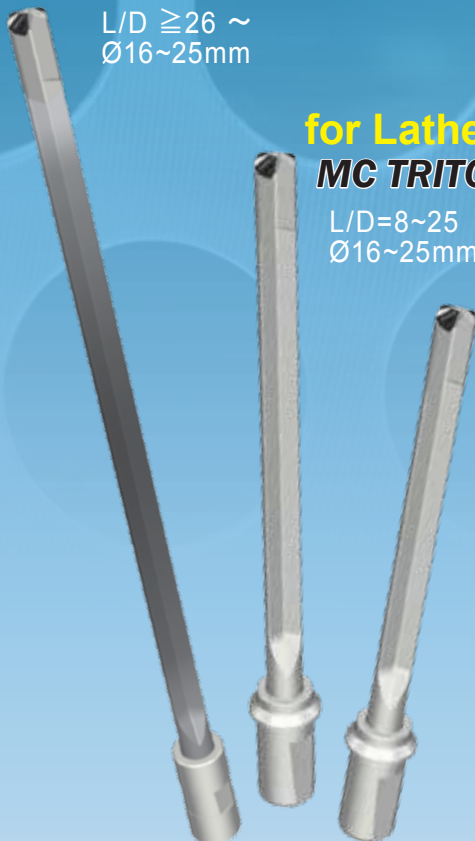

A drill for conventional machines which is designed based on our long experience and extensive know-how on deep hole drilling tools in BTA system

- No diameter setting necessary
- H class insert
- Hole tolerance IT10

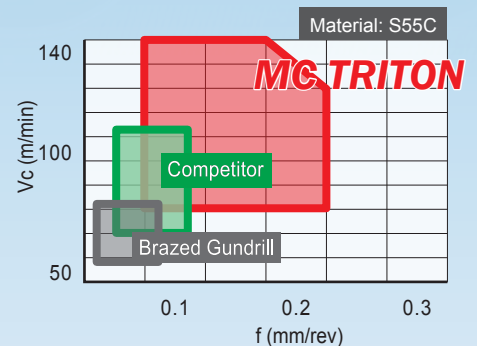
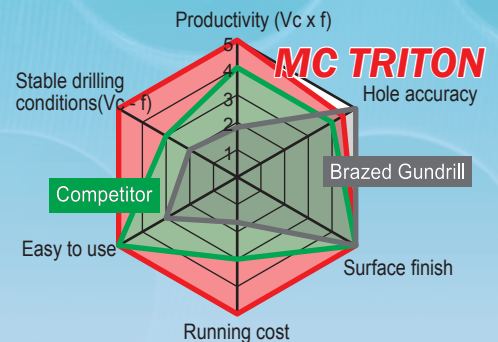

BTA direct mount tool - No diameter setting necessary

FINE Series



COMING SOON

FINE TRITON

- No diameter setting necessary
- H class insert
- Hole tolerance IT10



Now on Sale

FINE BEAM

- No diameter setting necessary
- H class insert
- Hole tolerance IT10



The first 3 corner H class insert in the market
NEW Insert!

TRITON Insert

